

BELOW THE WING FUELING STAIRS



KEY FEATURES

1. Fuel nozzle hanging basket
2. Durable powder-coating provides increased durability
3. Manual leveling jacks for ease of operation

OPTIONS

- Optional hot-dip galvanizing provides additional corrosion resistance
- Custom color choices available
- Manual/hydraulic leveling jacks available

Gas up & get going.

Get easy access to the airplane hatch with this hard-working stair that easily maneuvers to fit under the aircraft wing.



**GET FULL
PRODUCT
INFO**

SPECIFICATIONS

Capacity	500 lbs. (227 kg)	Running Gear	Swivel casters on front with a fixed rear axle for easy towing or positioning by hand
Casters/Tires	4 x 8 in. (10 x 20 cm) solid rubber tire	Leveling Jacks	Optional, available in manual or manual/hydraulic
Construction	Dictated by customer specs		

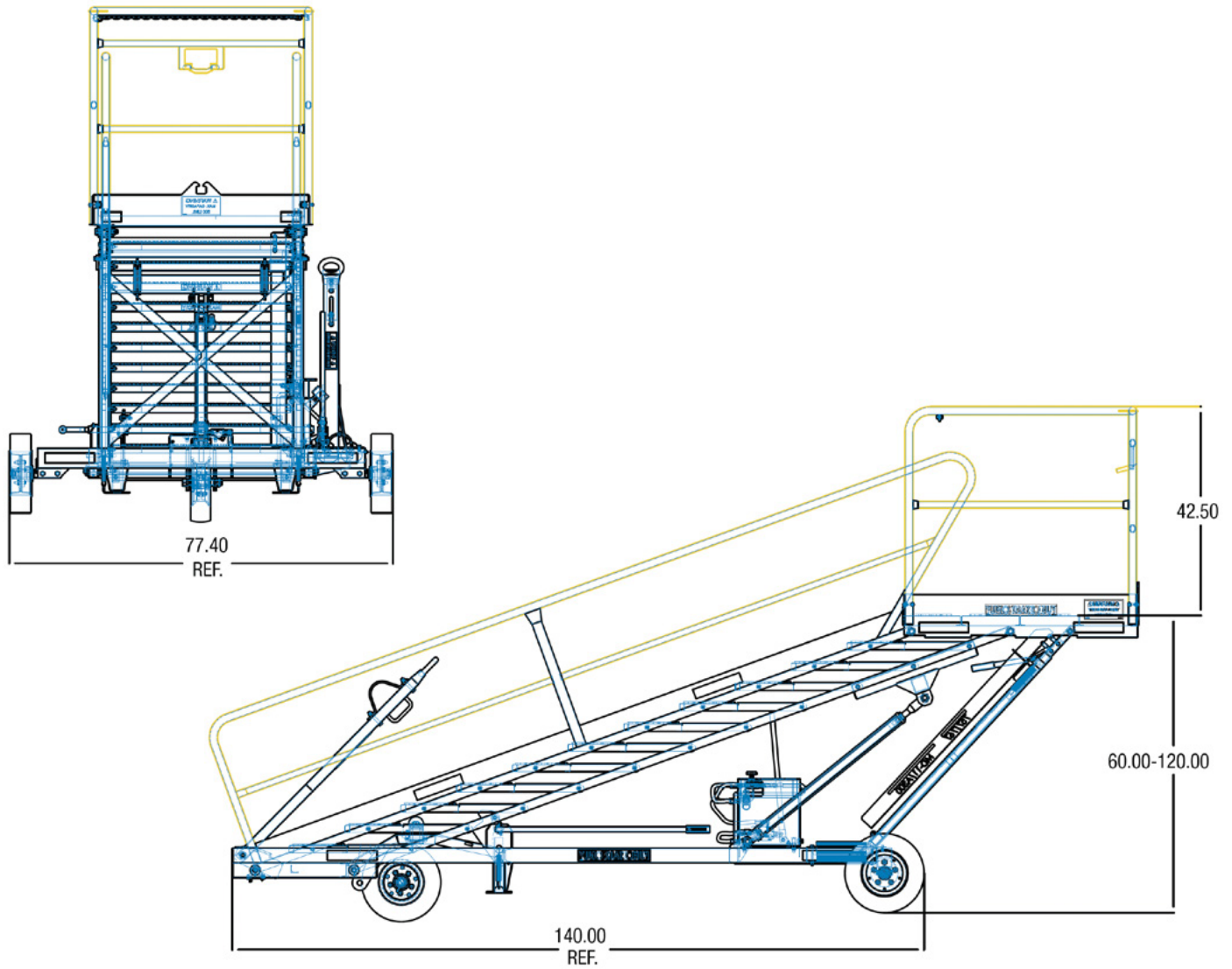

A world leader in airline, air cargo and material handling equipment for over 45 years.

FAST Global Solutions designs, builds, installs and services an expansive portfolio of robust, ruggedly-built, dependable equipment for today's global commerce operations. To learn more, contact the knowledgeable and experienced FAST Team.

GSE@fastsolutions.com +1 (320) 634-5126 fastsolutions.com