

BRAVO CART



Protect up to 8,000 lbs. from the elements.

Move more baggage faster with a reinforced steel cart designed for years of rugged use. This popular cart is stocked and ready to ship, offering faster turn-around times with no minimum quantities. The BRAVO Cart can also be ordered with options for customization.



KEY FEATURES

1. Vinyl curtains to protect baggage from the elements
2. Corner bumpers to protect from damage on the ramp
3. V-style floors to move moisture away and reduce baggage drag
4. Full 360-degree fifth-wheel rotation allows the carts to track in any direction for safety and easy maneuverability

OPTIONS

- Bolt-in shelves to manage baggage placement
- Rigid mount or four-wheel independent torsion axles
- Additional options are available for further customization
- Quick-Stop Brake compatible: Specifically designed to minimize potential hazards to ramp agents or aircraft strikes, the FAST Towbar Quick-Stop Brake is able to bring a moving baggage/cargo cart to a stop, if it accidentally becomes detached.



**GET FULL
PRODUCT
INFO**

SPECIFICATIONS

Capacity	8,000 lbs. (3,629 kg)	King Pin	2 in. (5 cm) diameter, stress-proof with sealed bearings
Weight	1,300–1,500 lbs. (590–680 kg)	Hubs	1.375 in. (3 cm) diameter sealed, tapered roller bearings
Box Length	116 in. (295 cm)	Body Panels	16-gauge
Width	66.25 in. outside of bumpers	Floor Panels	14-gauge, V-style
Height	80.1 in. rigid; 81.43 in. torsion (203–207 cm)	Tires	Solid three stage: 4 x 8 in. (10 x 20 cm) / 16 in. (41 cm) diameter
Track Width	52.75 in. (134 cm)	Running Gear	Rigid mount or four-wheel independent torsion axles
Rear Hitch	Spring-loaded E-hitch		

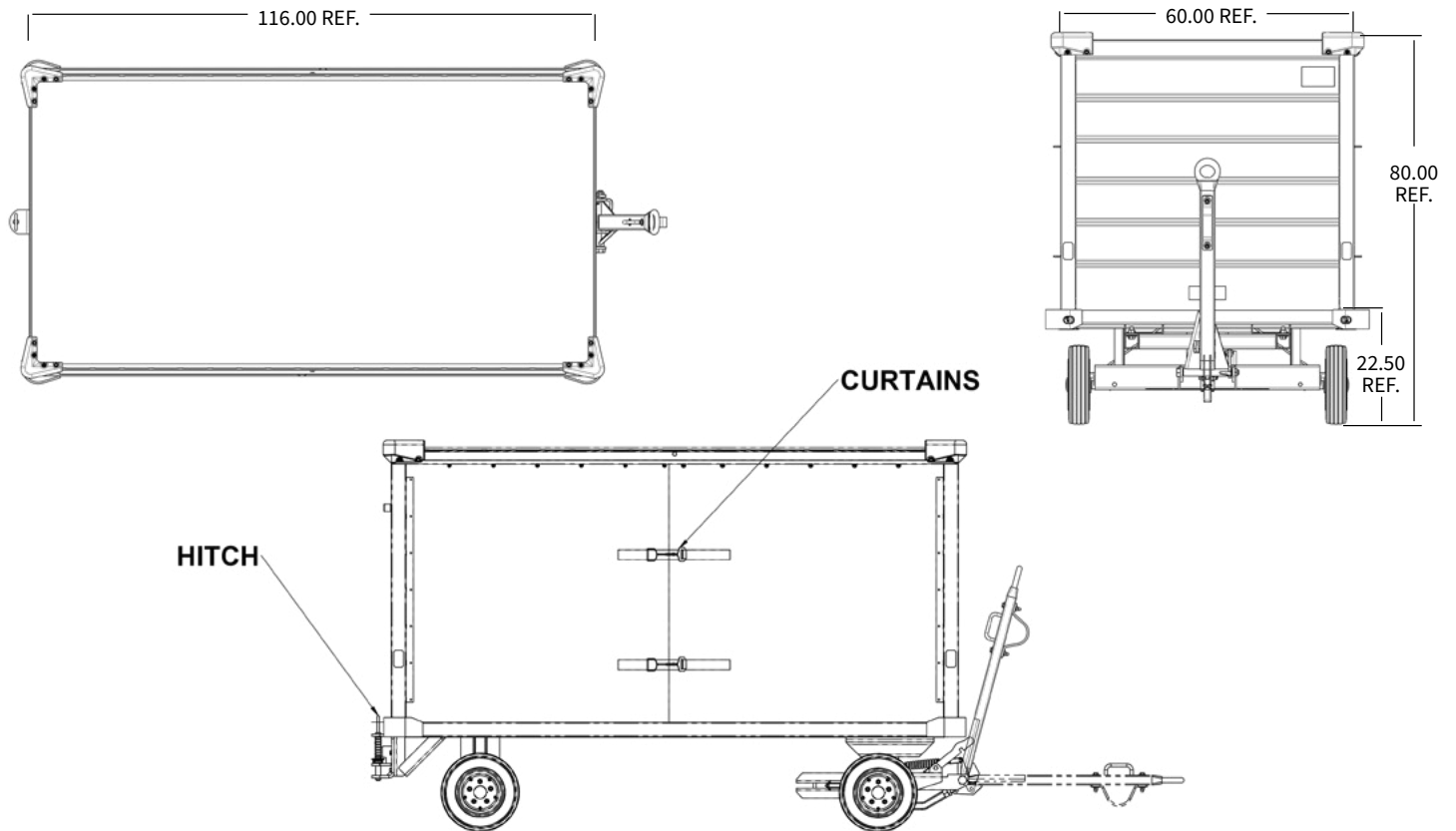

A world leader in airline, air cargo and material handling equipment for over 45 years.

FAST Global Solutions designs, builds, installs and services an expansive portfolio of robust, ruggedly-built, dependable equipment for today's global commerce operations. To learn more, contact the knowledgeable and experienced FAST Team.

GSE@fastsolutions.com +1 (320) 634-5126 fastsolutions.com