

DOOR TRANSITION ROLLERS

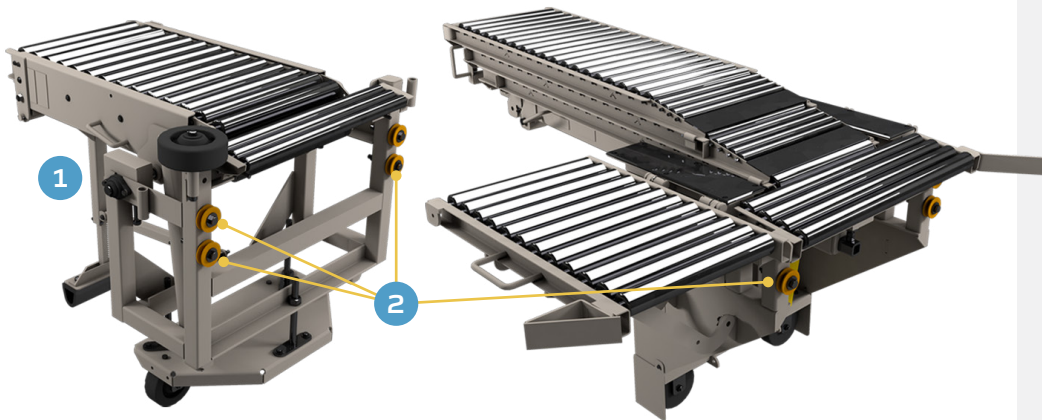

KEY FEATURES

1. Support legs adjustable on some units to load, unload or flat position
2. Mounted on T-rails to accommodate several stations
3. Manual boom extension provides appropriate length of roller conveyor surface to speed up load and unload
4. Stores in upright position to allow movement on platform

The ideal solution when you need extended reach beyond a single-stage conveyor.

Designed to assist with the loading and unloading of cargo containers and delivery trucks, covering the gap between door and transport conveyor. Can be mounted on T-rails adjacent to the conveyor to allow the unit to traverse to several different stations.



**GET FULL
PRODUCT
INFO**

SPECIFICATIONS

Retractable Length 42.5–76.8 in.

Extendable Length 61–168 in.

Width 33 in.

Load Capacity 50 lbs./ft.

Rollers 1.94 in. diameter; PVC

Operation Manual boom extension

Exact specifications will vary based on unit

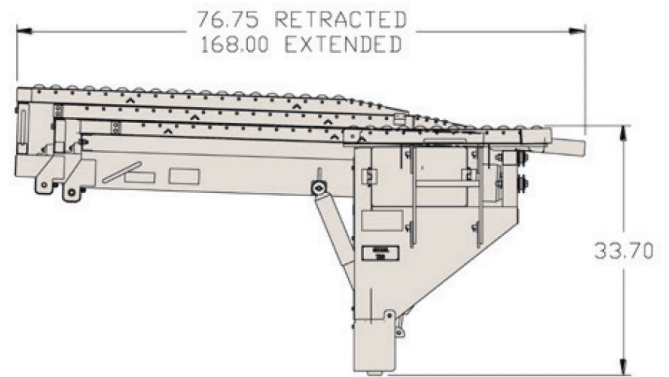
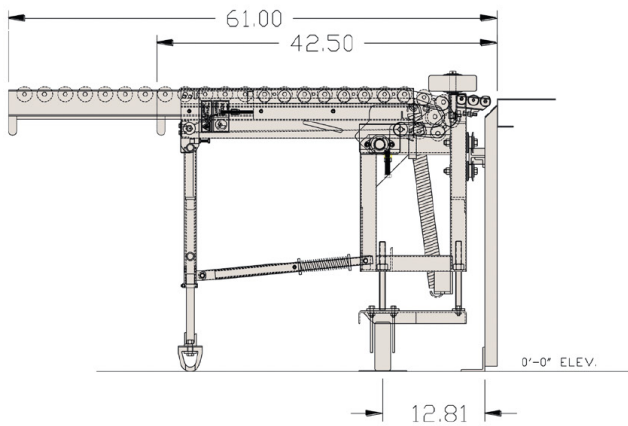
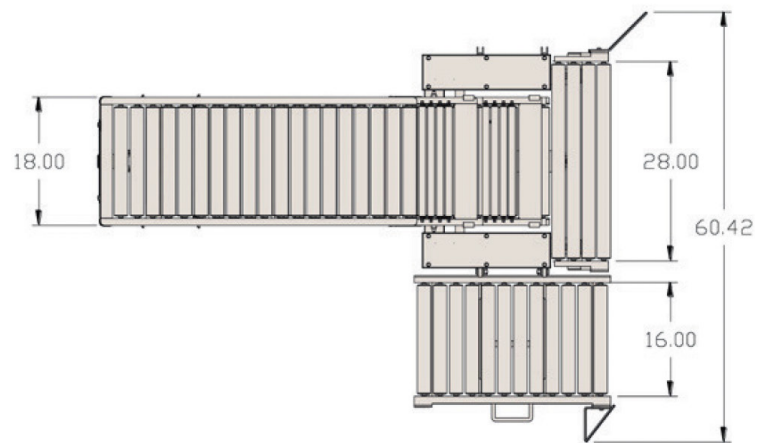
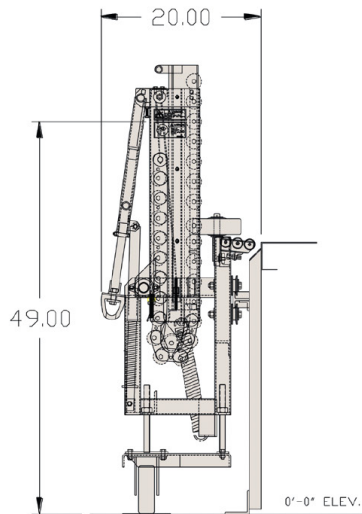

A world leader in airline, air cargo and material handling equipment for over 45 years.

FAST Global Solutions designs, builds, installs and services an expansive portfolio of robust, ruggedly-built, dependable equipment for today's global commerce operations. To learn more, contact the knowledgeable and experienced FAST Team.

conveyorsales@fastsolutions.com +1 (320) 634-5126 fastsolutions.com