

KNOCKDOWN CART



Ship five in the space of one

Reduce shipping costs and retain capacity with this innovative cart. Knock them down for shipping, and reassemble them upon arrival with just hand tools.

With just a few steps, 20 knockdown carts can be ready to ship in a single 40-foot container.

Thick-gauge steel, additional strengthening ribs, strong welds, premium hardware and a shot-blast/powder-coat process ensure the carts last and work efficiently for years.



KEY FEATURES

1. Each cart knocks down to a fifth of its size and can be stacked three to five high for shipping
2. Towbars prevent damage from jackknifing and enhance durability
3. Roll-on/roll-off capability allows easy maneuverability

OPTIONS & ACCESSORIES

- Customizable to meet requirements including: center shelves, back walls and curtain assemblies in baggage or cargo configurations
- Choose from rigid mount, shock mount or torsion axle configurations to suit any environment



**GET FULL
PRODUCT
INFO**

SPECIFICATIONS

Capacity	8,000 lbs. (3,629 kg)	King Pin	2 in. diameter stress-proof with sealed bearings
Weight	1,636 lbs. (742 kg)	Rear Hitch	Spring-loaded E-hitch; additional options available
Length	120–144 in. (305–366 cm)	Corner Bumpers	Smooth vinyl or optional Magee Finned
Width	67 in. (1.7 m)	Curtains	Vinyl with webbed reinforcement
Height	80.25–82.5 in. (2–2.1 m)	Running Gear	Rigid mount or 4-wheel independent rubber torsion axles
Track Width	52.75 in. (134 cm)		
Tires	Solid 4 x 8 in., 16 in. diameter with 9-gauge, 5-bolt, 4.5 in. BC, 2-piece demountable rims		

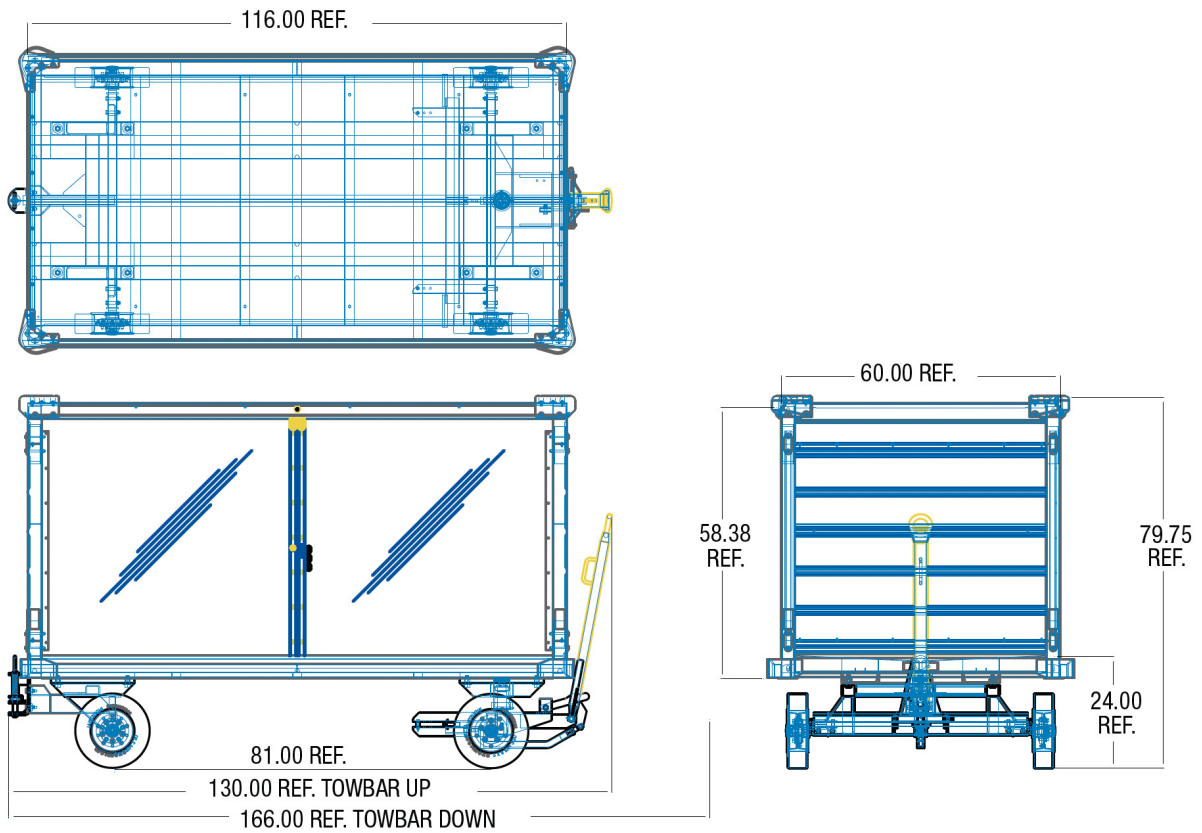

A world leader in airline, air cargo and material handling equipment for over 45 years.

FAST Global Solutions designs, builds, installs and services an expansive portfolio of robust, ruggedly-built, dependable equipment for today's global commerce operations. To learn more, contact the knowledgeable and experienced FAST Team.

GSE@fastsolutions.com +1 (320) 634-5126 fastsolutions.com