

# LYNX™ POWERED UNIT

(PATENT PENDING)

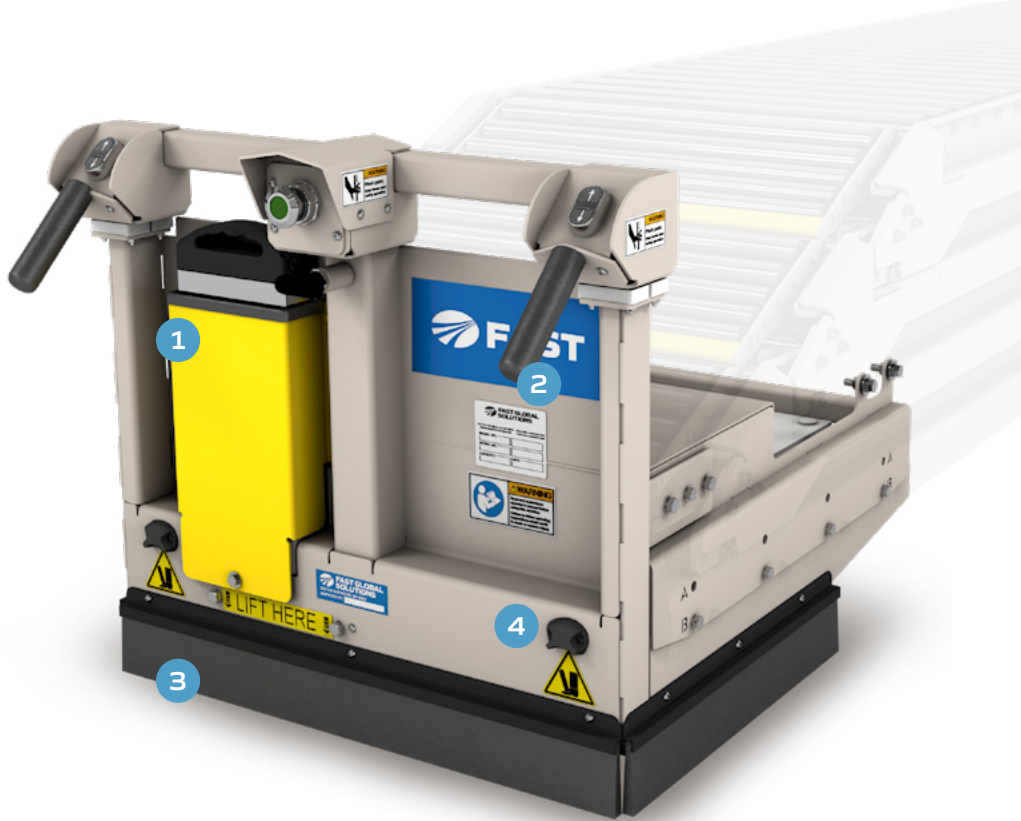

## KEY FEATURES

1. Self-contained 48 V battery powered unit, requires no wiring for installation
2. Operational handles adjust from 22–34 in. to accommodate operator
3. Brushes on front and sides keep unit clean and increase operator safety
4. Lights to illuminate travel path as RTL is extended

## OPTIONS

- SR-45 steel rail RTL as direct replacement of existing FAST low-profile RTL
- Battery Charging Station (Model #10-051805-01), for additional operation runtime

## Improve parcel loading operations and safety at the door.

Specifically designed for FAST gravity roller loaders, the Lynx Powered Unit attaches to the front of the RTL conveyor to aid the extension/retraction of the RTL for loading flatbed trucks and trailers. This powered unit allows a single operator to steer and more easily position the RTL pull-out extensions at variable lengths, to align with package wall depth changes. All controls are accessed from the front of the unit and lights on the end illuminate the travel path as the RTL is extended, to increase the safety and ergonomics for dock operators.

The Lynx Powered Unit is engineered for quick installation to existing RTL conveyors, with no additional cutting, wiring or welding needed.



**GET FULL  
PRODUCT  
INFO**

## SPECIFICATIONS

<b>Weight</b>	215 lbs. fully assembled
<b>Travel Speed</b>	≈ 0.75 mph in both directions
<b>Size</b>	Unit adds ≈ 6.5 in. to front of RTL; top of unit extends from 24.5–36.75 in.

<b>Battery</b>	48 V; operational charge lasts ≈ 15–25 trailers
<b>Powered Force</b>	<20 lbs. assisted push/pull force under normal conditions

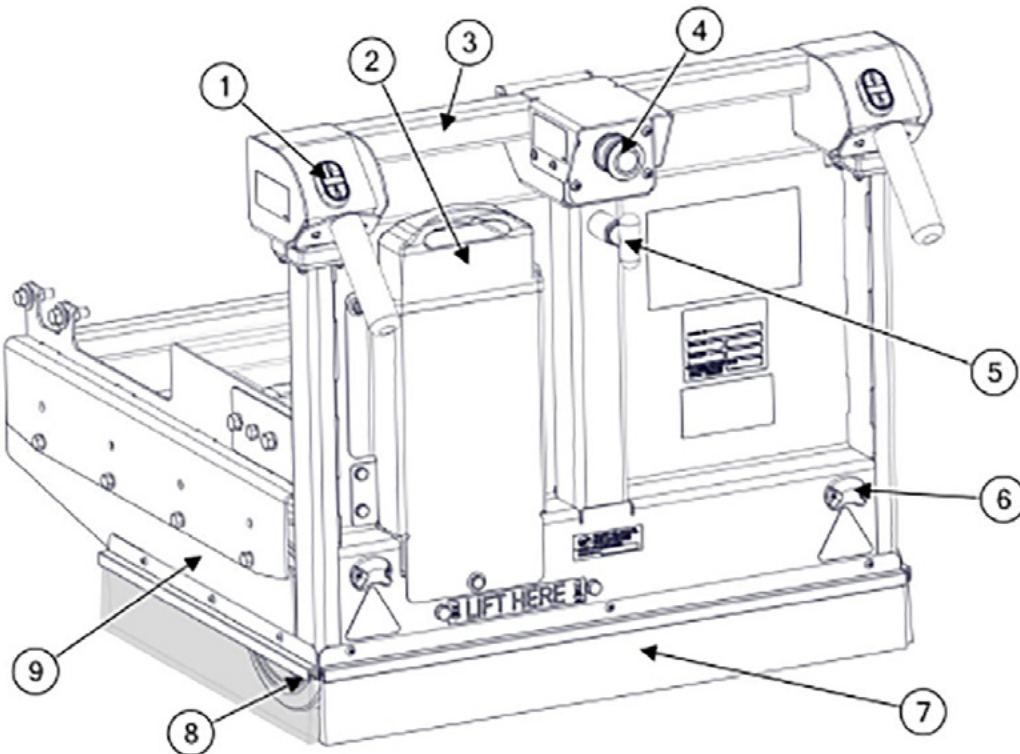

- |                           |               |
|---------------------------|---------------|
| 1. Directional Buttons    | 6. Lights     |
| 2. Battery                | 7. Brushes    |
| 3. Handle Assembly        | 8. Tires      |
| 4. On/Off Switch          | 9. Main Frame |
| 5. Handle Adjustment Knob |               |

**A world leader in airline, air cargo and material handling equipment for over 45 years.**

FAST Global Solutions designs, builds, installs and services an expansive portfolio of robust, ruggedly-built, dependable equipment for today's global commerce operations. To learn more, contact the knowledgeable and experienced FAST Team.

[conveyorsales@fastsolutions.com](mailto:conveyorsales@fastsolutions.com) +1 (320) 634-5126 [fastsolutions.com](http://fastsolutions.com)