

OPEN CART



Combine high capacity with easy loading

Heavy-duty open carts designed for transporting large loads with enhanced maneuverability, durability, and safety features. Built with reinforced steel construction for rigorous daily use in industrial environments.



KEY FEATURES

1. Reinforced 12-gage steel construction for years of rigorous daily use
2. End points can be fixed or removable for operational flexibility
3. Anti-friction bearings are permanently lubricated and sealed to keep out contaminants and reduce maintenance time
4. Fifth-wheel steering with full 360-degree rotation maximizes maneuverability
5. Towbar-actuated front-wheel brakes for increased safety

OPTIONS

- Rigid mounted or torsion axle running gear styles offer choices to suit each environment
- End and side panels can be fixed or removable, depending on the best option for your site
- Optional tarps and holders cover the cart for protection from the weather
- Hot-dip galvanizing provides additional corrosion resistance



**GET FULL
PRODUCT
INFO**

SPECIFICATIONS

Capacity	8,000 lbs. (3,629 kg) and 5,000 lbs. (2,268 kg) for a light-duty model	Hubs	1.375 in. (3 cm) diameter sealed, tapered roller bearings
Weight	1,240 lbs. (562 kg) and 1,100 lbs. (499 kg) for a light-duty model	Body Panels	16-gauge
Track Width	52.75 in. (1.3 m)	Floor Panels	12-gauge
Running Gear	Rigid mount or torsion axle	King Pin	2 in. (5 cm) diameter (1-1/2 in. [4 cm] in light-duty cart) stress-proof with sealed bearings
Rims	9-gauge, 5-bolt, 4.5 in. BC, 2-piece demountable	Rear Hitch	Spring-loaded E-hitch; additional options available
Tires	Solid in 4 x 8 in. (10 x 20 cm) and 16 in. (41 cm) diameter or 5 x 8 in. (13 x 20 cm) and 18 in. (46 cm) diameter sizes	Reflectors	Eight 3 in. (8 cm) diameter, amber on front and red on rear; additional options available
Wheel Spindles	1-5/8 in. (4 cm) diameter replaceable		

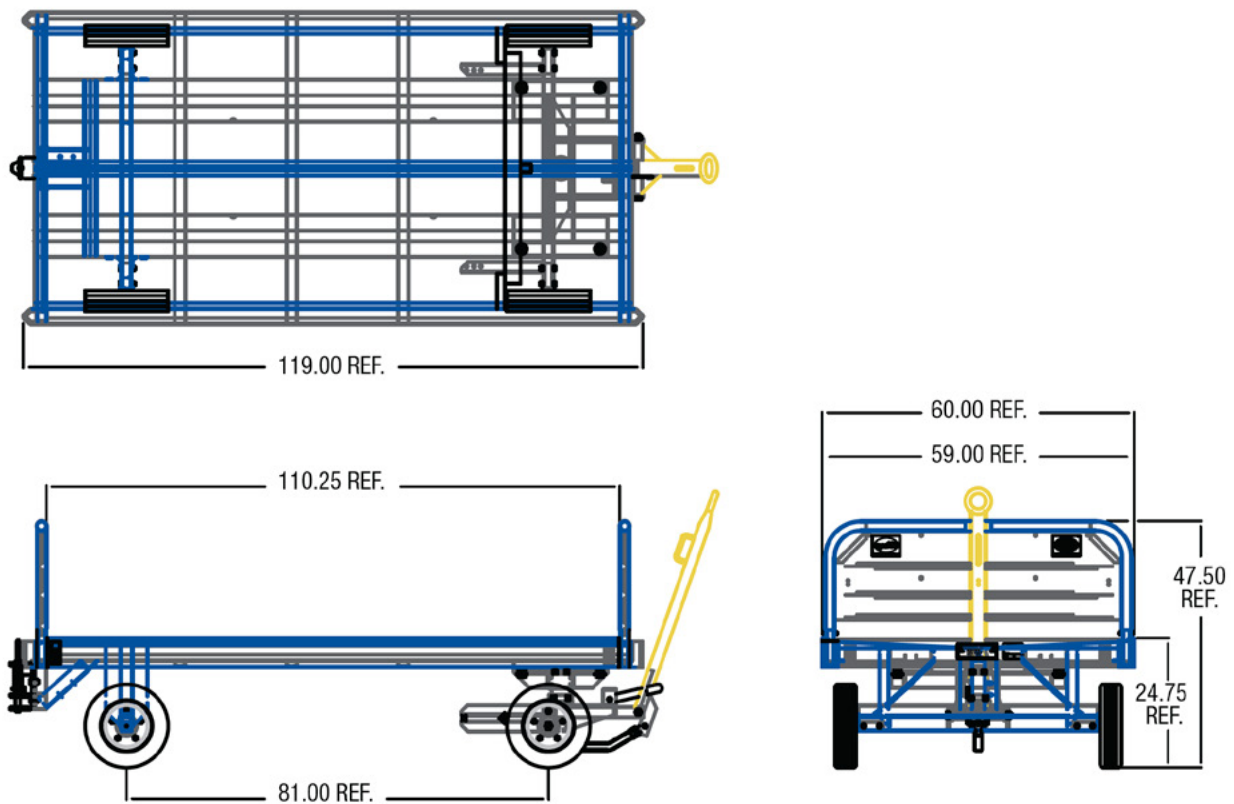

A world leader in airline, air cargo and material handling equipment for over 45 years.

FAST Global Solutions designs, builds, installs and services an expansive portfolio of robust, ruggedly-built, dependable equipment for today's global commerce operations. To learn more, contact the knowledgeable and experienced FAST Team.

GSE@fastsolutions.com +1 (320) 634-5126 fastsolutions.com