

TOWBAR QUICK-STOP BRAKE

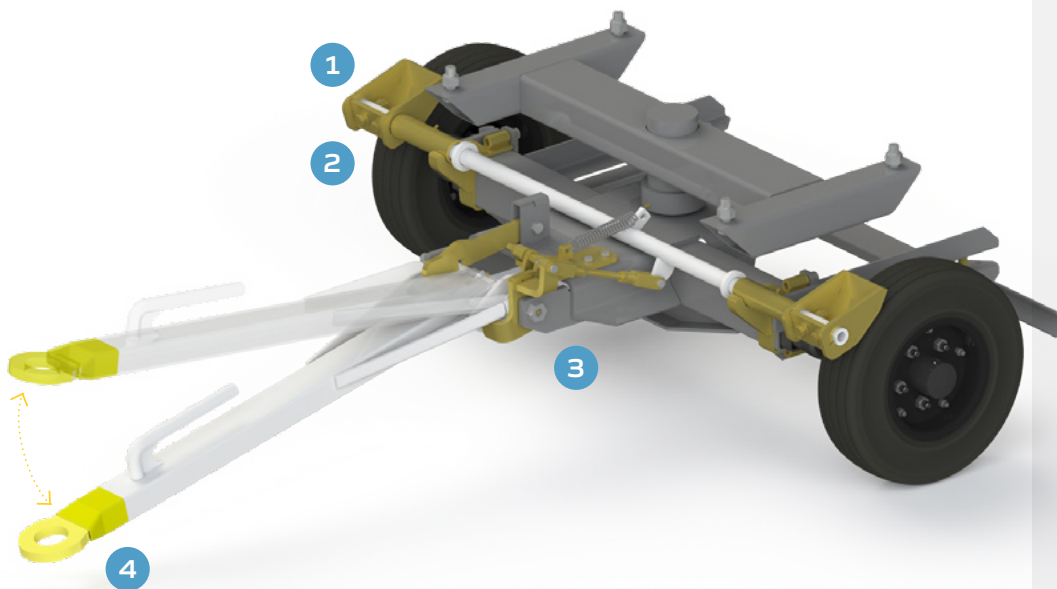

KEY FEATURES

1. Dual-side tire braking system
2. Heavy-duty steel components for durability and longevity
3. Compatible with current FAST towbar-activated brake systems
4. Quick-Stop Brake activated if towbar falls below standard towing height
5. Brake engages automatically in event of accidental detachment

Prevent runaway baggage carts.

Specifically designed to minimize potential hazards to ramp agents or aircraft, the FAST Towbar Quick-Stop Brake is able to bring a moving baggage cart to a swift stop if it accidentally becomes detached. Should a towbar fall below a standard horizontal towing height, the Quick-Stop Brake components are activated to apply substantial pressure to the right- and left-side tires on the front running gear—working to bring the cart to a halt. Minimal adjustment to kit required as new tires become worn.

The Towbar Quick-Stop Brake can either be an original equipment installation or retro-fit/replacement of existing towbars to improve safety on the ramp.



**GET FULL
PRODUCT
INFO**

A world leader in airline, air cargo and material handling equipment for over 45 years.

FAST Global Solutions designs, builds, installs and services an expansive portfolio of robust, ruggedly-built, dependable equipment for today's global commerce operations. To learn more, contact the knowledgeable and experienced FAST Team.

GSE@fastsolutions.com +1 (320) 634-5126 fastsolutions.com