

ROLLER BED CONTAINER DOLLY

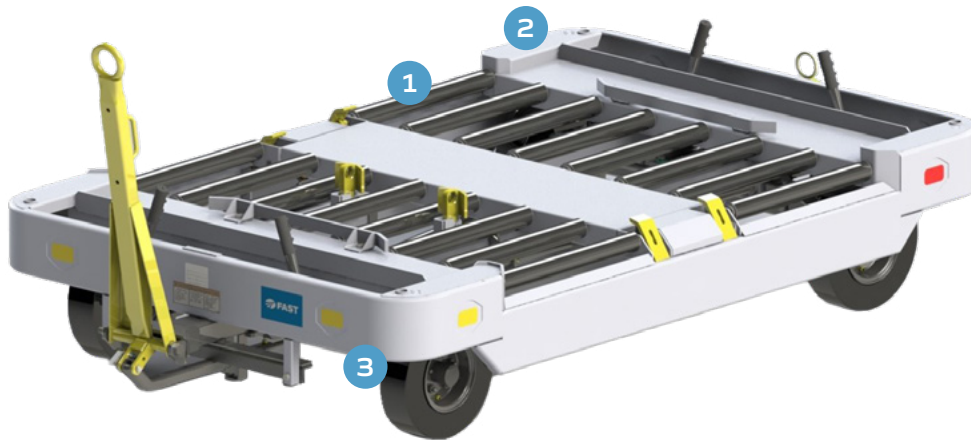

Move two containers at a time.

This dolly has a 3,500 lbs. (1,588 kg) capacity. Quality components and durable safety features come standard. Able to handle LD-2 or LD-3 containers.

KEY FEATURES

1. Heavy-duty rollers with sealed bearings maximize longevity
2. U.S. Military-grade powder coating provides increased durability
3. Towbar actuated front wheel brakes for increased safety

OPTIONS

- Optional hot-dip galvanizing provides additional corrosion resistance
- Choose towbar-activated front-wheel brakes or lever-controlled rear-wheel brakes for securing the dolly in place
- Customized paint colors



**GET FULL
PRODUCT
INFO**

SPECIFICATIONS

Capacity	3,500 lbs. (1,588 kg)	Rear Hitch	E-hitch and pintle hook
Weight	1,400 lbs. (633 kg)	Brakes	Towbar-activated front-wheel brakes
Length	107 in. (272 cm)	Tires	Solid size: 4 x 8 in. (10 x 20 cm) / 15.75 in. (40 cm) diameter
Width	67 in. (170 cm)	Bed Rollers/ Casters	2.5 in. (6 cm) diameter rollers with sealed bearings
Track Width	60 in. (152 cm)	Container Stops	Manual-over-center type with vertical restraint
Hubs	1.5 in. (3.8 cm) or 1.38 in. (3.5 cm) diameter with sealed bearings		

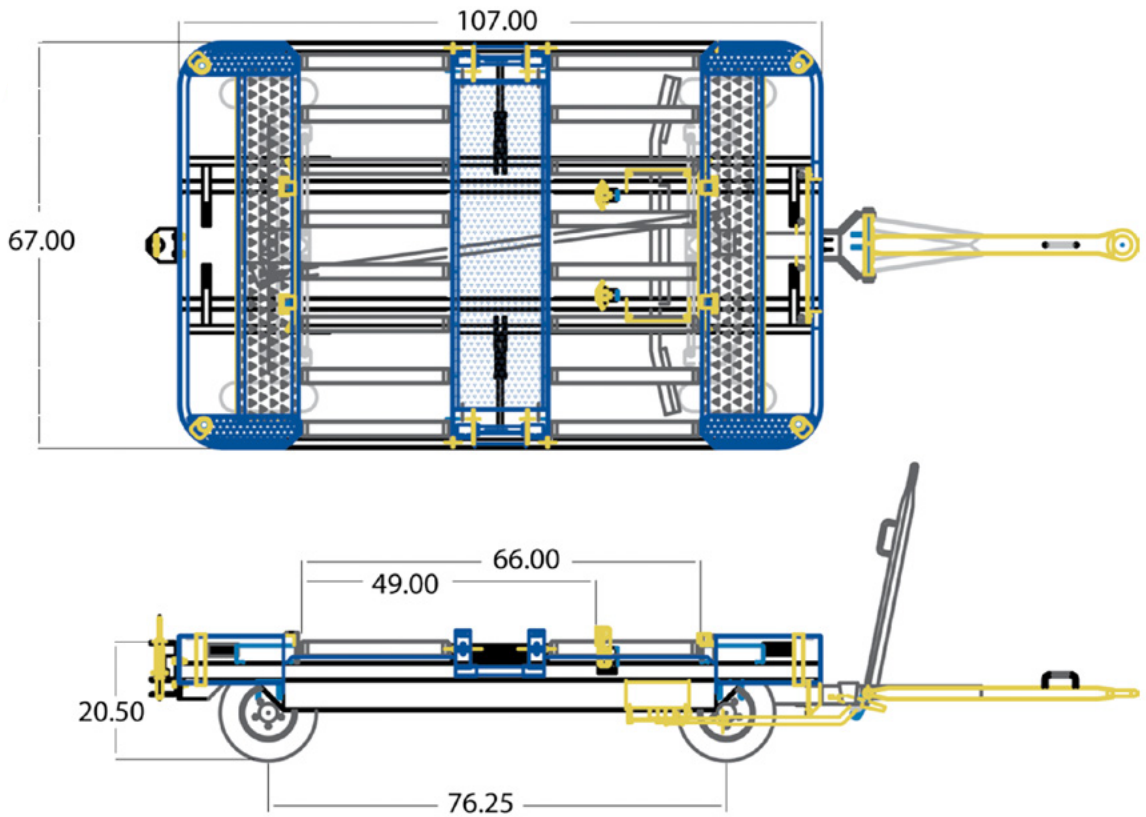

A world leader in airline, air cargo and material handling equipment for over 45 years.

FAST Global Solutions designs, builds, installs and services an expansive portfolio of robust, ruggedly-built, dependable equipment for today's global commerce operations. To learn more, contact the knowledgeable and experienced FAST Team.

GSE@fastsolutions.com +1 (320) 634-5126 fastsolutions.com