

SMALL PACKAGE BINS



Accumulate small packages for destination determination.

Designed to integrate into sorter conveyor systems and efficiently hold accumulated small packages as they flow from gravity chutes. Available in 12-way, 18-way, 24-way or 30-way bin structures, with optional rectangular or circular configuration, to align with the needs of the operation.

KEY FEATURES

1. Constructed of heavy-duty steel
2. Available in 12-way, 18-way, 24-way or 30-way bin structures

OPTIONS

- Optional rectangular or circular configuration
- Models available with heavy-duty casters for more frequent maneuverability



**GET FULL
PRODUCT
INFO**

SPECIFICATIONS

Bin Structure	12, 18, 24, 30-way	Height	84.5–87.4 in.
Width	75.2–78.1 in.	Configuration	Rectangular or circular
Depth	48 in.	Construction	Galvanized steel

Circular

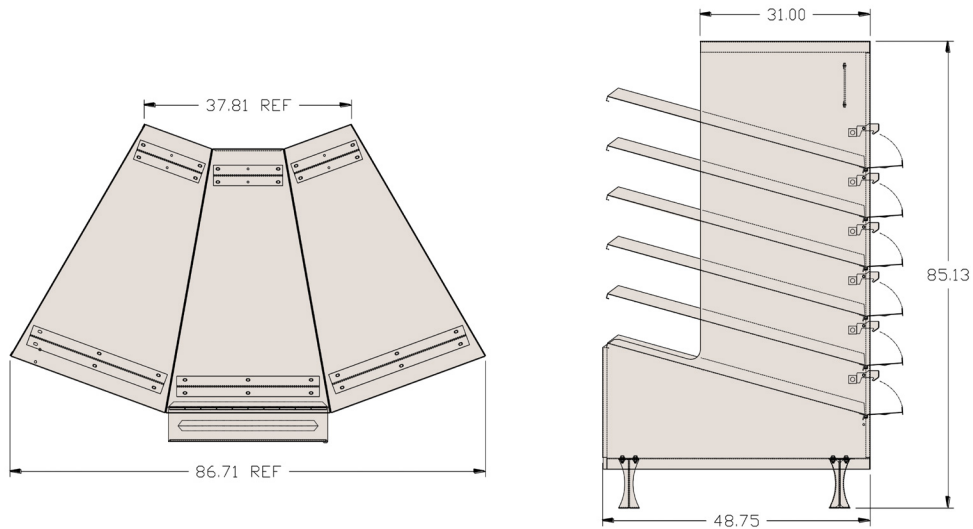

Rectangular

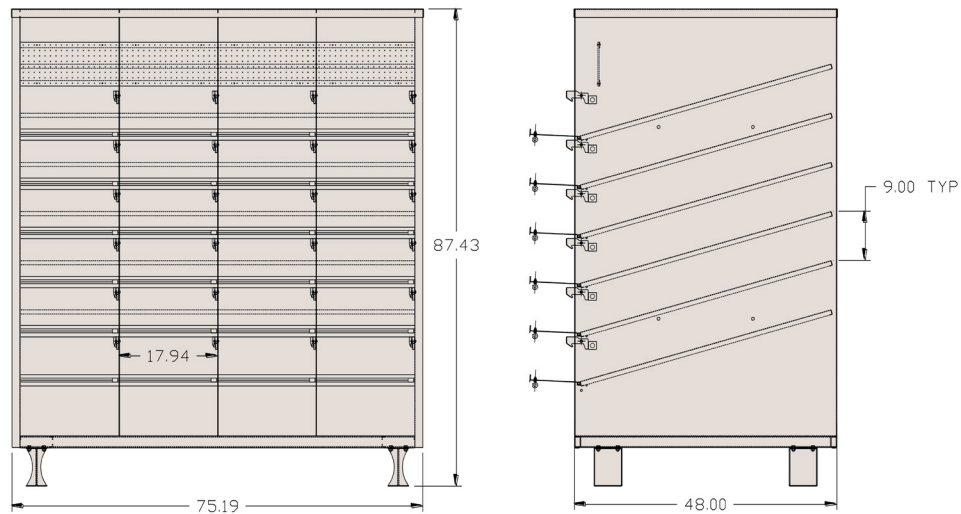

A world leader in airline, air cargo and material handling equipment for over 45 years.

FAST Global Solutions designs, builds, installs and services an expansive portfolio of robust, ruggedly-built, dependable equipment for today's global commerce operations. To learn more, contact the knowledgeable and experienced FAST Team.

conveyorsales@fastsolutions.com +1 (320) 634-5126 fastsolutions.com