

SORTER DESTINATION CHUTE

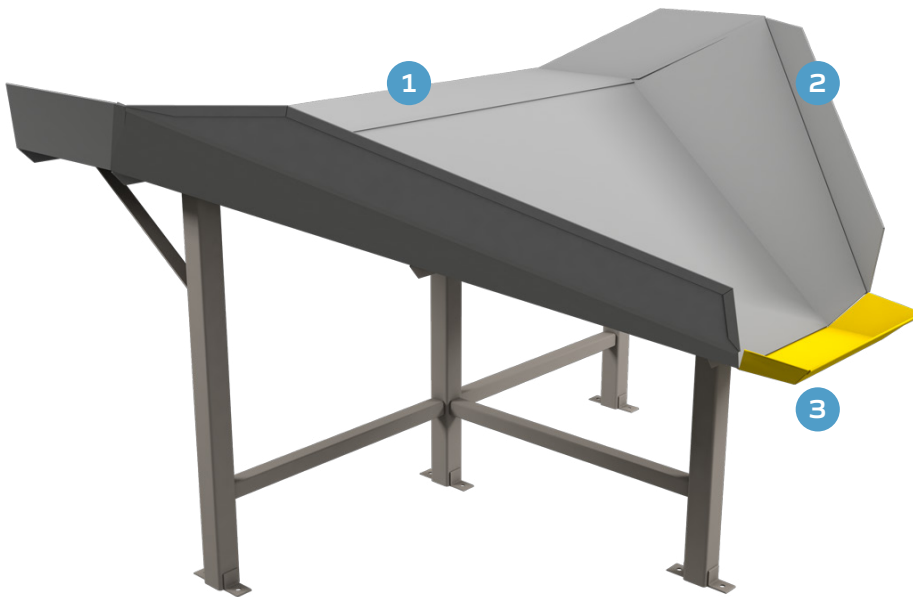

Easily singulate package flow for destination determination.

Designed to integrate into a sorter conveyor system, providing separate gravity flow channels directed towards destination sorting bins or other accumulating equipment. Customize the number of channels and size to match the operation's sorting system.

KEY FEATURES

1. Durable, smooth galvanized steel surface
2. Integrated side panels to manage separate channel paths
3. Extension at bottom of chute
4. Constructed of heavy-duty steel

OPTIONS

- Optional heavy-duty bolt-up or weld-up assembly construction
- Optional low-friction material lining for increased package flow rate



**GET FULL
PRODUCT
INFO**

SPECIFICATIONS

Dimensions 10–2 ft. tapers

Elevation 18 in. drop

Construction Concave galvanized steel bed

Coating Optional low-friction material lining

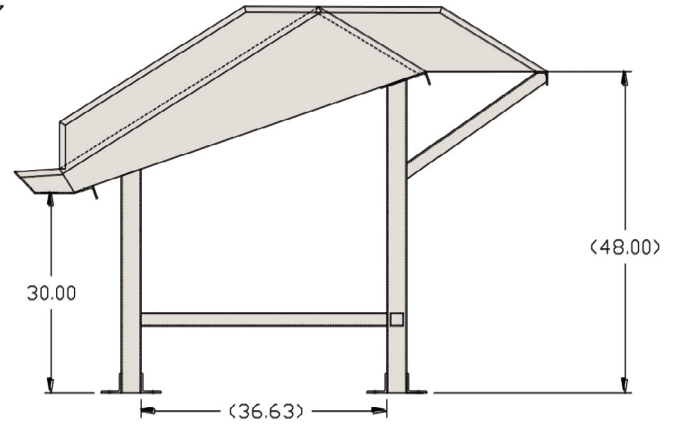
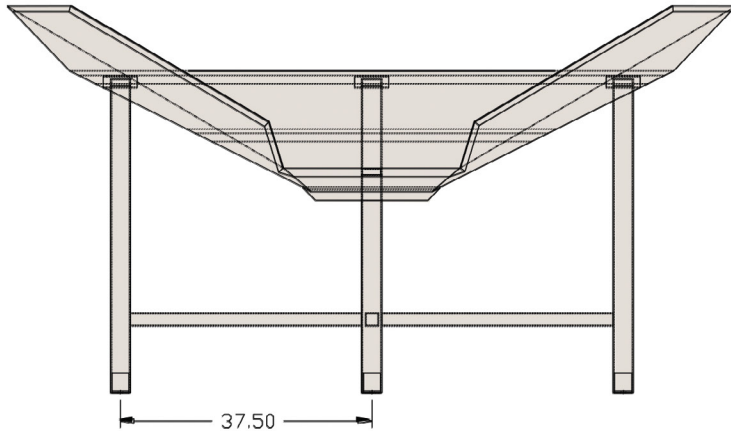

A world leader in airline, air cargo and material handling equipment for over 45 years.

FAST Global Solutions designs, builds, installs and services an expansive portfolio of robust, ruggedly-built, dependable equipment for today's global commerce operations. To learn more, contact the knowledgeable and experienced FAST Team.

conveyorsales@fastsolutions.com +1 (320) 634-5126 fastsolutions.com