

# SPIRAL BOX CREW STAIRS



## KEY FEATURES

1. Durable, lead-edge rubber bumpers protect the aircraft
2. Adjustable height
3. The tubular steel main frame easily supports as much as 1,000 lbs. (454 kg)
4. The towbar-actuated parking brake effortlessly secures each unit
5. Premium casters move the solid urethane tires into place with a 10 in. (250 cm) diameter swivel

## OPTIONS

- Choose from fixed or adjustable height options. The fixed 185 in. (4.7 m) height gives stability at a common loading height while the adjustable height, from 171–195 in. (4.3–5 m) offers flexibility for various aircraft.
- Optional hot-dip galvanizing provides additional corrosion resistance.

## Stability at fixed and adjustable heights.

Get more platform space and greater stability to keep your crew members safe with fixed or adjustable height spiral-box stairs.



**GET FULL  
PRODUCT  
INFO**

# SPECIFICATIONS

<b>Platform Height</b>	Fixed at 185 in. (470 cm) or Adjustable from 171–195 in. (434–495 cm)	<b>Tires</b>	10-ply pneumatic, 20.5 x 8 x 10 in. (52 x 20 x 25 cm)
<b>Capacity</b>	1,000 lbs. (454 kg)	<b>Construction</b>	Tubular steel main frame with anti-slip steps and platforms
<b>Running Gear</b>	Casters on front with a fixed rear axle	<b>Parking Brakes</b>	Towbar-activated
<b>Casters</b>	10 in. diameter swivel with solid urethane tires		

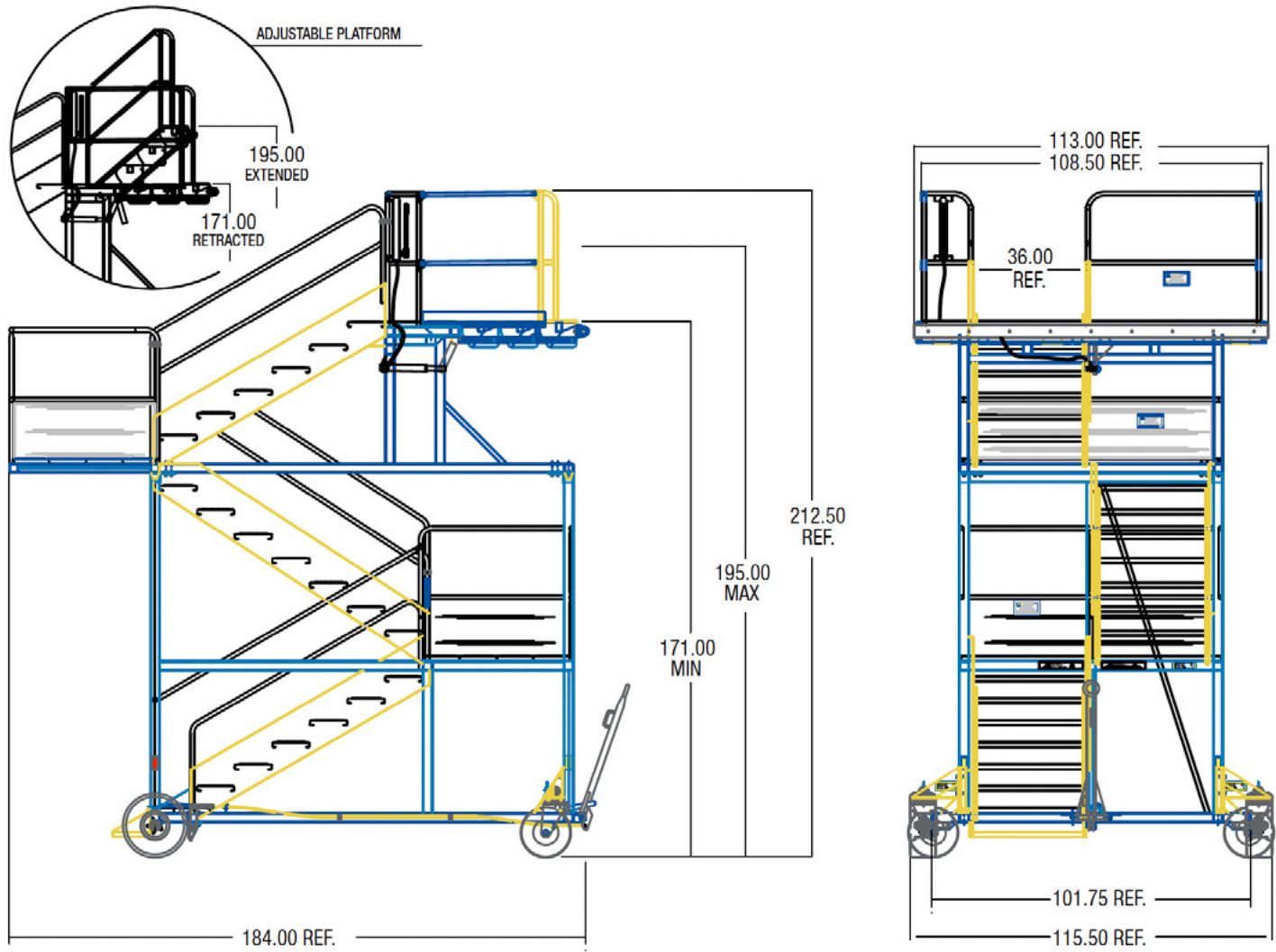

**A world leader in airline, air cargo and material handling equipment for over 45 years.**

FAST Global Solutions designs, builds, installs and services an expansive portfolio of robust, ruggedly-built, dependable equipment for today's global commerce operations. To learn more, contact the knowledgeable and experienced FAST Team.

[GSE@fastsolutions.com](mailto:GSE@fastsolutions.com) +1 (320) 634-5126 [fastsolutions.com](http://fastsolutions.com)