

WALK-BEHIND BELT LOADER



Powered walk-behind loader improves speed and efficiency

Keep luggage and packages moving with our walk-behind belt loader. You'll get the cost savings and maneuverability of a walk-behind unit with greater durability than a drivable machine. Simply leave the loader near the gate and use the stowable tiller arm for precise placement at the plane. By eliminating the drive components found in most belt loaders, we've not only increased longevity and reduced cost, but we've also significantly reduced maintenance requirements. And our durable components and rigorous testing ensure your loader will last and work efficiently for years. Safe, continuous operation with no downtime: that's how we keep you moving.



KEY FEATURES

1. Fixed guardrails keep luggage and packages moving
2. Operator controls on each end of the loader ensure easy access from any position
3. The roller-supported belted bed operates in forward and reverse for load and unload operation
4. Automatic hydraulic braking and five emergency stop buttons for safety
5. Easily load and offload at a variety of aircraft heights, accommodating door sill bases to up to 119 in. (3 m) off of the ground

OPTIONS

- Rear lift kits incorporate a second hydraulic lift to accommodate varying worker or truck transfer heights on the end opposite the aircraft
- Retractable or flip-up side guides available



**GET FULL
PRODUCT
INFO**

SPECIFICATIONS

Length	237 in. (602 cm) standard; 296 in. (751 cm) optional	Tires	5.7 x 8 in. (15 x 20 cm) rear and 6.9 x 9 in. (18 x 23 cm) front pneumatic
Unit Width	34.75 in. (88 cm)	Dynamic Brakes	Automatic
Belt Width	24 in. (61 cm)	Parking Brake	Orscheln lever and cable manual disc
Belt Speed	0–100 ft. per minute (0–30 m per minute)	Fuel Pump	Mechanical
Belt Support	Roller bed	Fuel Tank	Steel with sight gauge and vented cap
Steering Type	Manual	Fuel Tank Capacity	15 gal. (60 L)
Transmission and Drive Axle Type	Hydraulic motor/differential	Hydraulic Tank	Steel with sight gauge and breather cap
Transmission and Drive Axle Speed	Variable forward and reverse	Hydraulic Tank Capacity	18 gal. (68 L)

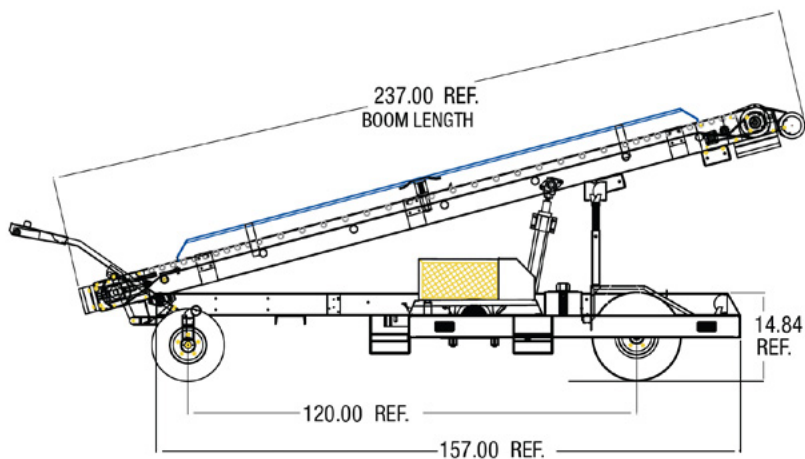
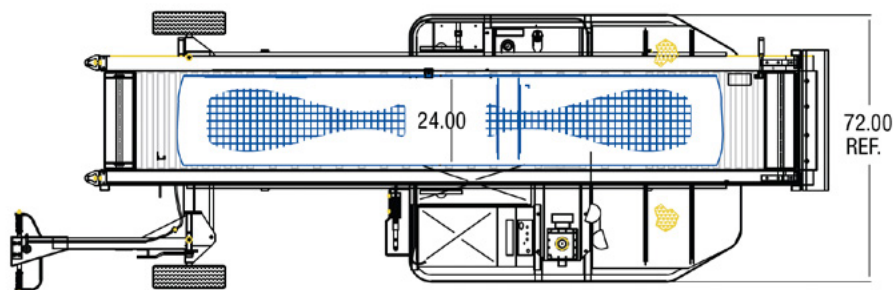

A world leader in airline, air cargo and material handling equipment for over 45 years.

FAST Global Solutions designs, builds, installs and services an expansive portfolio of robust, ruggedly-built, dependable equipment for today's global commerce operations. To learn more, contact the knowledgeable and experienced FAST Team.

GSE@fastsolutions.com +1 (320) 634-5126 fastsolutions.com